



Dredger Technology

The Complete Solution for Electrical Systems



**SAM
Electronics**

an  communications company

Dredger Technology

Power Generation, Distribution and Electric Drives on Dredgers

Dredging vessels are designed for excavation activities usually carried out at least partly under-water, in shallow water or fresh water areas with the purpose of gathering up bottom sediments and disposing of them at a different location, mostly to keep waterways navigable. To perform these tasks dredgers are equipped with different specific dredging devices as follows:

- Submersible and onboard dredge pumps
- Cutter head at the suction inlet
- Jet pump for jet water to cutter or drag head
- Main and thruster propulsion to drive and manoeuvre the dredging vessel

- Side and ladder winches to move the vessel and the ladder during dredging operation

On modern dredgers the specific dredging devices above are designed with electric drives as all electric ship. The electric plant is designed according to the „power station principle“ with diesel alternators feeding a common bus bar system and all electric drives as well as the mains connected to this bus bar. The main propulsion plant is designed as a subordinated consumer, the output being automatically reduced in accordance with consumption of other consumers

if this exceeds the output of the supplying generator set. In order to ascertain at any time a stable operation of the power station, the power consumption of the propulsion plant is automatically reduced if:

- The number of supplying diesel generator sets is reduced
- The apparent currents of the diesel generators reach their nominal value
- The active power of the diesel generator sets exceeds the nominal value
- The speed of the diesel generator sets decreases below the admissible value

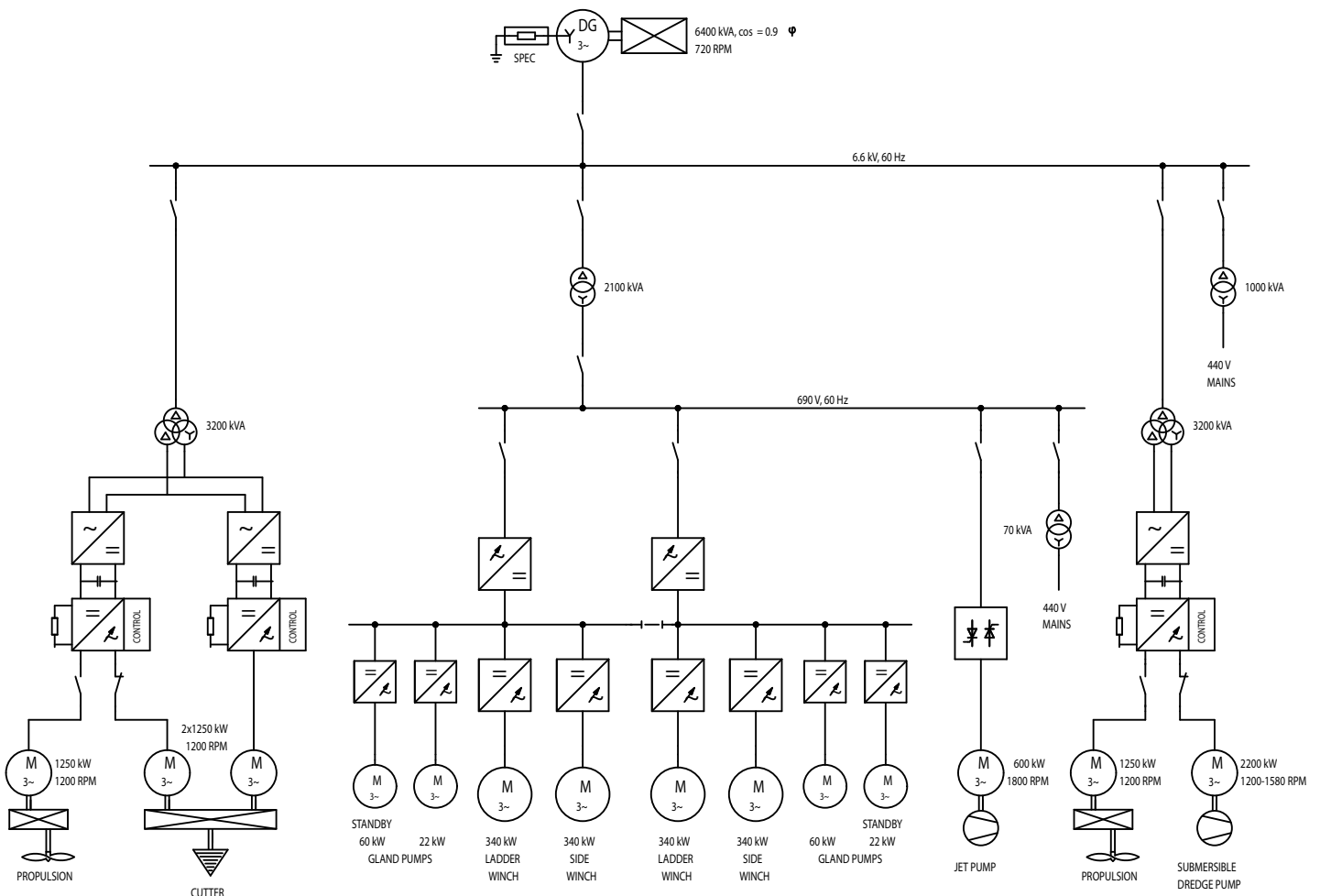

Single line diagram of power generation, distribution and electric drives on cutter suction dredger

Dredge Control and Monitoring System (DCMS)

Dredge Control Technology for the entire Dredging Process

- Control and monitoring of the dredging process
- Automatic functions and procedures
- Production monitoring
- Reporting, logging and trending
- Dredge chart operations (survey system)
- Diagnosis for ship's machinery systems

For Suction Hopper Dredgers

- Suction pipe position monitoring (STPM)
- Draught and loading monitoring (DLM)

For Cutter Dredgers

- Automatic cutter control (ACC)

Maximum efficiency and minimum personnel expenditure are essential for the successful operation of dredgers. Designed to match this requirement SAM products for dredging applications are based on industrial state-of-the-art hardware components.

SAM dredger control technology permits control of the entire dredging process from one central station (one man operation). All relevant data for production and cost optimized control of the dredging operations are displayed to the dredger master.

The most advanced SAM systems, optionally adapted to special customer requirements, fully integrate the different functions, avoiding costly interfacing problems.

Of course, these functions can also be provided as separate SAM stand-alone standard systems matching the latest technology as well.

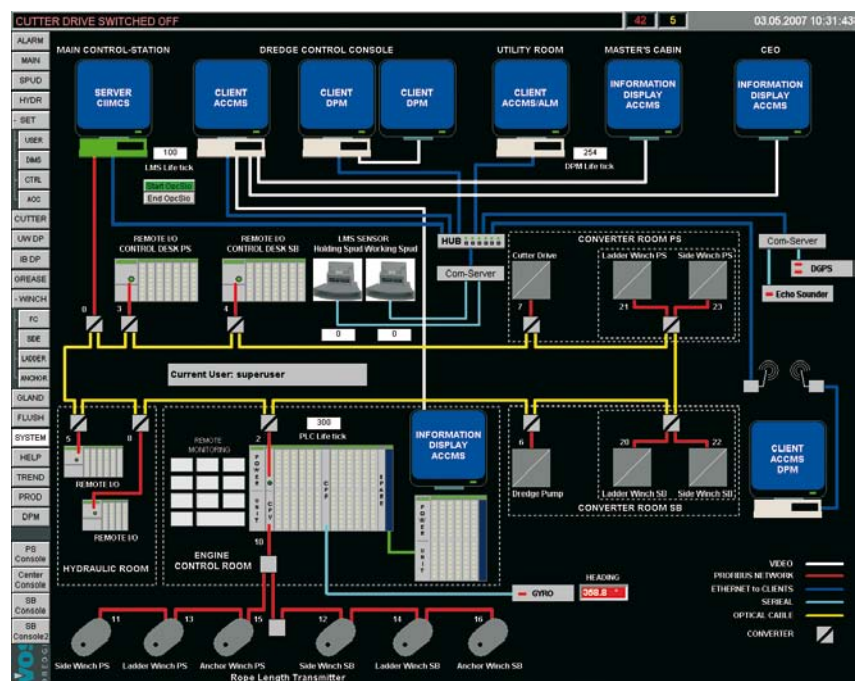

Dredge control and monitoring system network mimic

Partnership in Dredger Technology

SAM Electronics and VOSTA LMG cooperate in the field of dredger automation. Technological knowledge and experience in both companies, since many years, guarantee a brilliant design of complete dredger automation systems.



Dredger Technology

Trailing Suction Hopper Dredgers

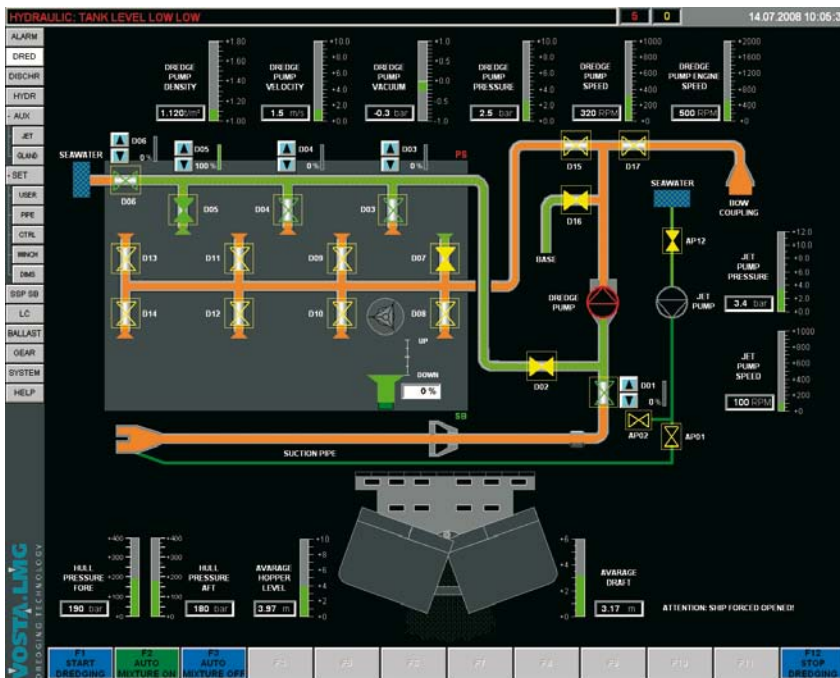

Dumping mimic of split hopper dredger



Trending and logging mimic

Process Control

The dredge control and monitoring system is a highly integrated system with decentralised process interfaces, centralised controlling units and human interfaces.

The control and monitoring system combines all required monitoring and control functions of the complete dredging installation by means of different, task oriented mimic diagrams.

The human interface system consists of a series of mimic screens divided in functional groups. The basic design philosophy of the pages is to provide an easy-to-learn and easy-to-use „man-machine-interface“ (MMI).

The mimics show in real time the status of the equipment. All relevant process data are shown in bar graphs.

The final structure and layout of the screen pages will be developed in close co-operation with the client in order to meet the operator's specific needs.

Reporting, Data Logging and Trending

This system measures all process data required for operation directly with a specific interface.

All data record will be sensed and logged at a constant and specified interval, and will be capable of tracking for operational history analysis or for fault tracing by the operating and maintenance staff.

The recording and retrieval system will be flexible enough in its use and setup to issue progressive production reports, with downtime summaries. These reports will be capable of being produced for a variable but specified time span. Alarm history is to be recorded, displayed and printed as necessary.

Suction Tube Position Monitoring (STPM)

Pipe position indicator etc. are basic parts of the integrated system. All the system actuators and sensors are connected to a PLC system. The PLC system as well as the PC based visualization provided from SAM Electronics avoid interfacing and adjustment problems.

The position of the side suction pipe is shown on a mimic screen with reference to the side of the ship. Using the values of various sensors the STPM calculates the position and depth of the pipe. The calculation considers the values of the inclinometers and angle transmitters on the pipe, the draught and heel transmitter as well as the tide and the calculated trim.

Draught and Loading Monitoring (DLM)

The draught and loading monitor is used for continuous, quantitative determination of the dredged material.

The system provides the operator with a quick and complete overview of the status of the ship (draught, trim, heel and hopper level), the operational data displacement, load and solid and the operation mode. The measured and calculated data are shown on a dedicated screen in a clear manner, displaying all relevant data.

Reports can be printed per trip, consisting of the most important data values and the loading/unloading diagram. The main trip data is also stored for later reporting and evaluation by third party systems using office tools like Excel.

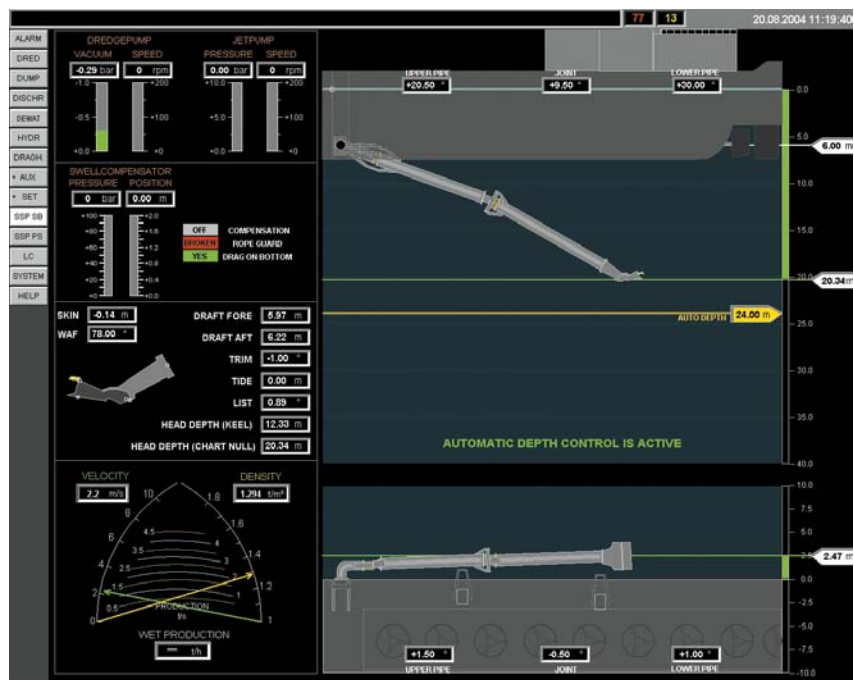

Suction pipe position monitoring mimic

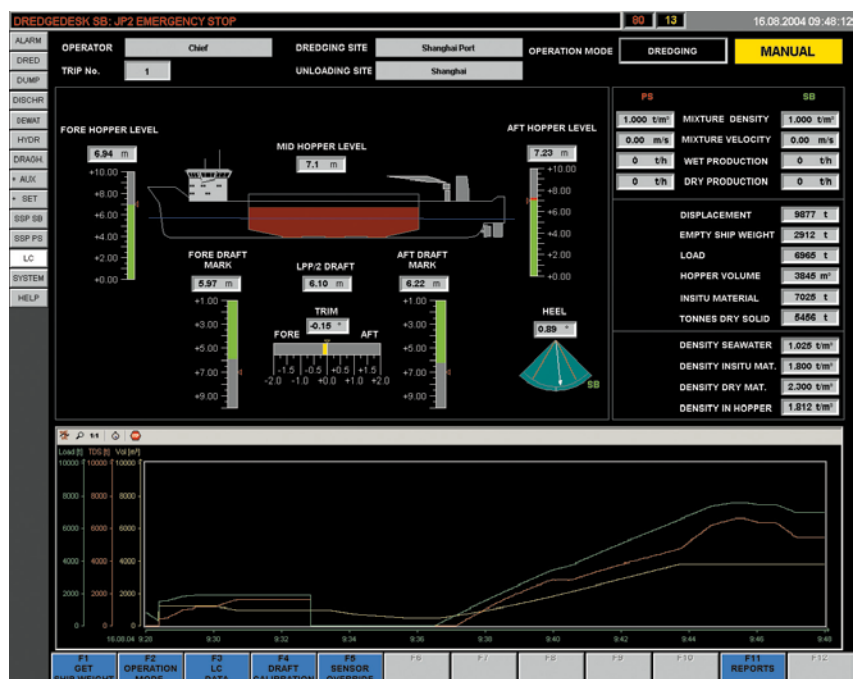

Display draught and loading monitor mimic

Dredger Technology

Cutter Suction Dredgers

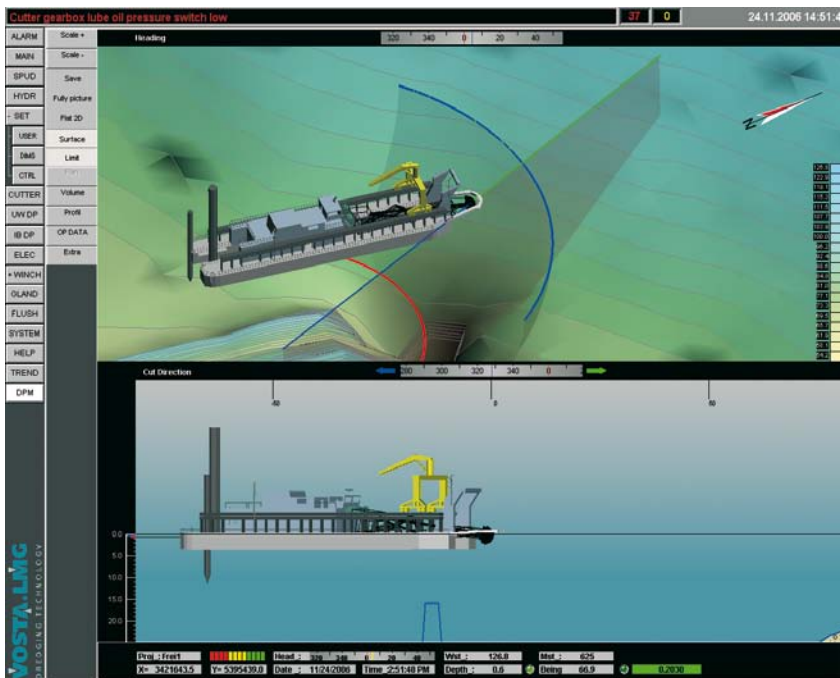

Dredge profile monitoring mimic

Cutter Dredger Control

The control and monitoring system for cutter dredgers consists of decentralised process interfaces and centralised controlling units. The PLC and the remote I/O components are either connected via a fast industrial network. The system combines all required monitoring and control functions of the complete dredging installation by means of different, task oriented mimic diagrams. The work station at the dredgemaster desk is for the visualisation of the process.

This system typically includes an Automatic Cutter Control (ACC) system for cutter head and cutter wheel dredger, which acquires and processes all data necessary for automatic dredging processes.

Data is relayed from dredge drives via industrial network or serial interfaces. All signals and computed values are available for multi-display presentation. Profile data, feed values and alarm limits are entered via a control computer keyboard also allowing the selection of different operating modes.

*Cutter suction dredger
"Batang Anai"*



Automatic Cutter Control (ACC) in Different Modes

- Constant depth, the ground is removed in a horizontal layer
- Profile, the ground is removed in vertical profile layers. The cutter is moved between the profile limits
- Same track back, the ground is to be excavated by moving the dredger along the same track from starboard to port and back again
- Monitor operation, all measurement and computation values are displayed on the monitor. The dredger drives are controlled manually
- Semi automatic operation, for reworking of banks. This mode is a combination of profile and monitor operation. The side winches are operated manually where as the ladder winch follows the programmed profile.

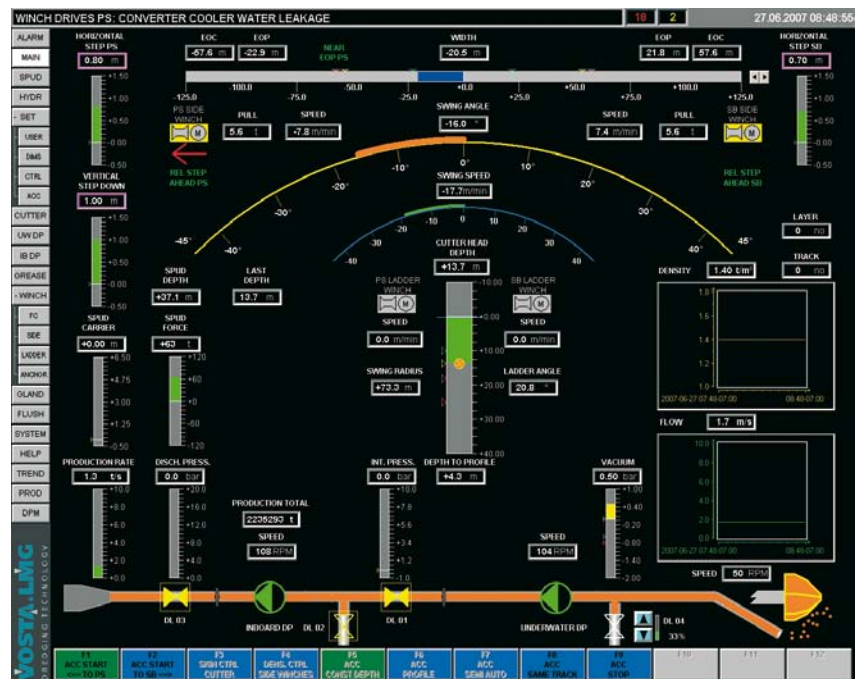

ACC overview mimic



Cutter suction dredger
"DCI DREDGE XVIII"

Dredger Technology

Special Solutions

Pontoon - Special Solution

In the field of process automation and control the SAM Electronics has realized a special solution for dynamic positioning and tracking of a spraying pontoon for land reclamation in close cooperation with Jan de Nul B.V. one of the largest dredging companies.

- Positioning of the pontoon with four hydraulic winches
- Automatic movement along predefined tracks
- Automatic control of pontoon speed or layer thickness

The integrated monitoring and control system for the pontoon contains:

- Process overview and control
- Input of setvalues and parameters
- Diagnostics
- Alarm monitoring
- Logging and trending

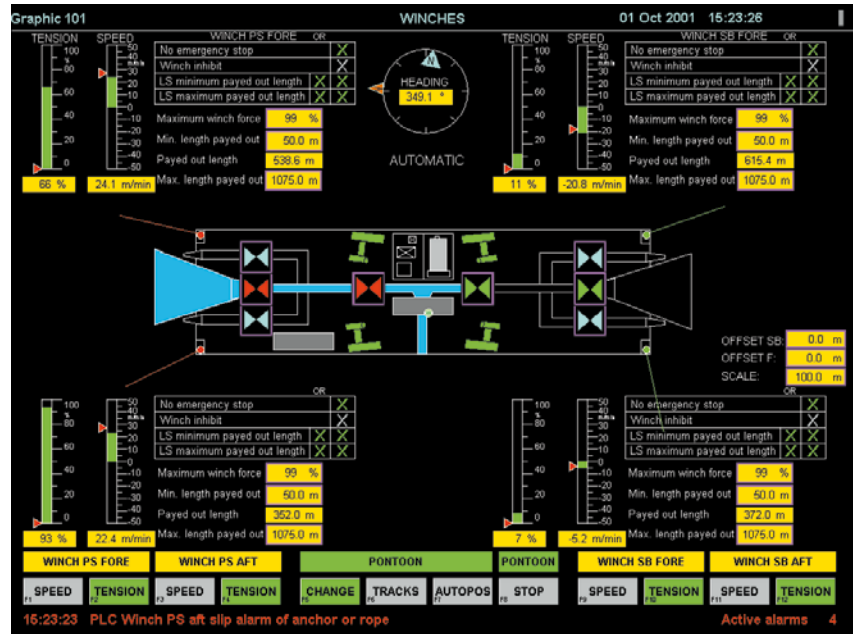

Pontoon: process overview mimic



Spraying pontoon